



CP100-B (backpack)

Dedicated VFD for water supply

Shenzhen Socon Electric Co.,Ltd.

Add:Building B, Langxin Commercial Center, Langxin Community,
Shiyan Street, Bao'an District, Shenzhen, China.

Web:www.socon.com.cn



Function advantages

「 Auto-Adjustment & Unattended 」

One key start, the system runs automatically; Automatic wake-up and sleep; Automatically add or remove the pump and always maintain constant pressure; Automatically adjust the frequency of each pump to achieve the best energy-saving effect.

「 Precise pressure 」

built-in special PID function for water supply can realize accurate and constant pressure water supply, Rapid response to sudden change of water pressure to ensure rapid recovery of water pressure.

「 Backpack installation 」

Through the adapter plate, it is directly installed on the water pump body without cabinet. The installation is fast and economical.

「 Multiple protection 」

IP54 protection, Built in completed water pump, VFD and pipe network pressure protection function to ensure the long-term stable and reliable working.

「 Intelligent anti rust and freezing 」

The water pump that has not worked for a long time in the water shall be working regularly to avoid the normal use of the water pump due to rust or freezing.

「 Automatic restart 」

After power failure and recovery, CP100-B will automatically put in to operation to ensure continuous water supply.

「 Redundancy design 」

In the multi pump system, the dual master mode can be set. When one master fails and stops, the other master will automatically put into operation to ensure the continuous water supply of the system.
(CP100-BH Series has not this function).

「 Multi pumps rotation 」

The master pump and slave pump can operate alternately regularly to prolong the service life of the system.
(CP100-BH Series Has not this function).





CP100-BH series

CP100-BH series is the third generation of backpack constant pressure water supply VFD. Low power, Simple operation, designed for family using.

Specification

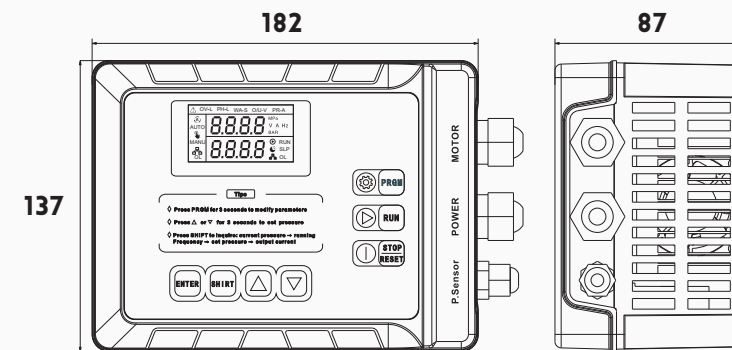

MODEL	OUTPUT POWER (KW)	OUTPUT CURRENT (A)
CP100-2S-0P4BH	0.4	2.3
CP100-2S-0P7BH	0.75	4
CP100-2S-1P5BH	1.5	7
CP100-2S-2P2BH	2.2	9.6

Keyboard operation and characteristic

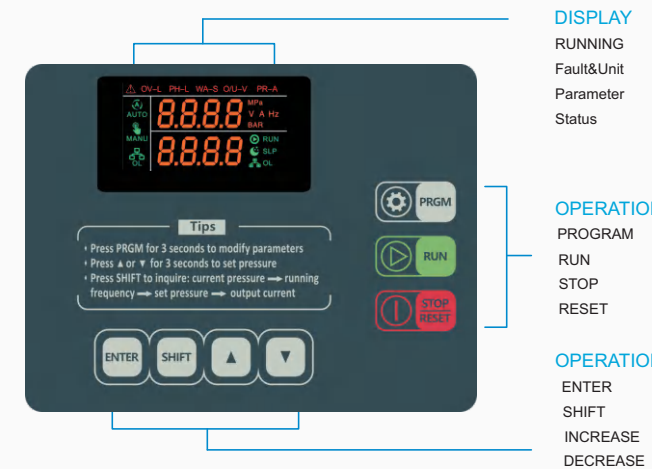

DISPLAY
RUNNING
Fault&Unit
Parameter
Status

OPERATION
PROGRAM
RUN
STOP
RESET

OPERATION
ENTER
SHIFT
INCREASE
DECREASE

- ◆ Color display and keys, friendly operation
- ◆ 2 lines of display, convenient display and operation
- ◆ Visually reading status and errors
- ◆ The keyboard film is made of PET, with good wear resistance and long life

Wiring

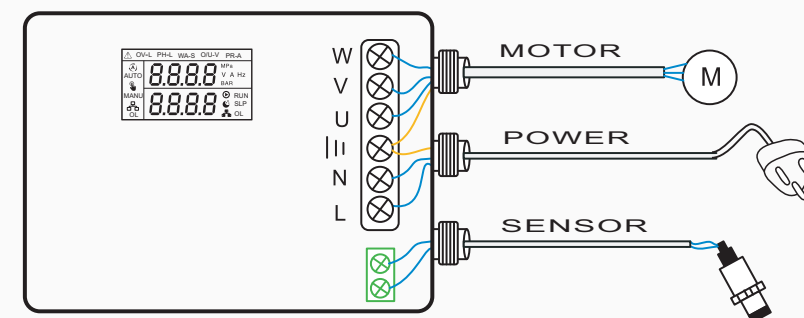

- ◆ Factory configuration
 - (1). 0.7m motor cable
 - (2). 2m input power cable with plug.
 - (3). 2m pressure sensor and sensor.
 - (4). Knapsack adapter.



CP100-B series

CP100-B is a backpack constant pressure water supply VFD. Small volume, accurate constant pressure, simple operation, stability and reliability. It is widely used in fire water supply, building water supply, etc..

Dimension and specification

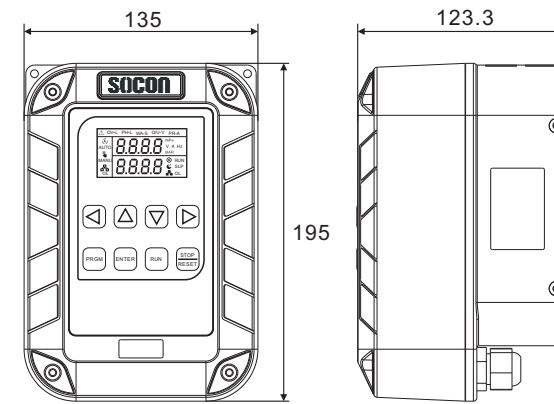

Structure A

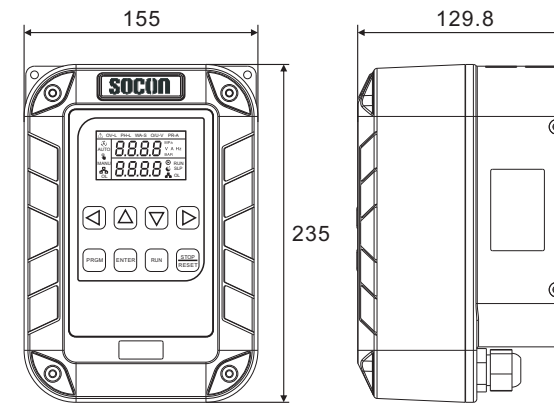

Structure B

	MODEL	OUTPUT POWER (KW)	OUTPUT CURRENT (A)
Structure A			
1PH 220V	CP100-2S-0P7B	0.75	4
	CP100-2S-1P5B	1.5	7
	CP100-2S-2P2B	2.2	9.6
3PH 380V	CP100-4T-0P7B	0.75	2.8
	CP100-4T-1P5B	1.5	4.4
	CP100-4T-2P2B	2.2	5.8
Structure B			
3PH 380V	CP100-4T-4P0B	4.0	10
	CP100-4T-5P5B	5.5	13
	CP100-4T-7P5B	7.5	17

Keyboard operation and characteristic

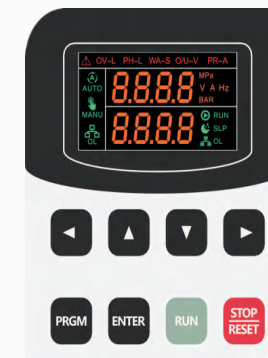

DISPLAY

RUNNING
Fault&Unit
Parameter
Status

OPERATION

ENTER
SHIFT
INCREASE
DECREASE

OPERATION

PROGRAM
RUN
STOP
RESET

- ◆ Color display and keys, friendly operation
- ◆ 2 lines of display, convenient display and operation
- ◆ Visually reading status and errors
- ◆ The keyboard film is made of PET, with good wear resistance and long life

Applications



Sales network

